

- 
1. The domain of the function  $\log(\log \sin(x))$  is
- (A)  $0 < x < \pi$  (B)  $2n\pi < x < (2n+1)\pi \quad n \in \mathbb{N}$   
 (C) Empty set (D) None of the above
2. A relation R is defined in  $N \times N$ , such that  $(a, 2)R(c, 4)$  iff  $a = b + 3$ .  
 The relation R is:
- (A) Reflexive but not transitive  
 (B) Reflexive and transitive, but not symmetric  
 (C) An equivalence relation  
 (D) A partial order
3. Consider a set  $A\{1, 2, 3, \dots, 1000\}$ . How many members of A shall be divisible by 3 or by 5 or by both 3 and 5
- (A) 467 (B) 533  
 (C) 599 (D) 66
4. The power set of the set  $\{\phi\}$  is
- (A)  $\{\phi\}$  (B)  $\{\phi, \{\phi\}\}$   
 (C)  $\{0\}$  (D)  $\{0, \phi\}$
5. Palindromes cannot be recognized by any FSM because,
- (A) An FSM cannot remember arbitrarily large amount of information  
 (B) An FSM cannot deterministically fix the midpoint  
 (C) Even if the midpoint is known, an FSM cannot find whether the second half of the string matches the first half or not  
 (D) All of the above
6. According to pumping lemma for context free languages:  
 Let L be an infinite context free language: then there exists some positive integer m such that any  $w \in L$  with  $|w| \geq m$  can be decomposed as  $w = u v x y z$
- (A) With  $|vxy| \leq m$ , such that  $uv^i xy^i z \in L$  for all  $i = 0, 1, 2, \dots$   
 (B) With  $|vxy| \leq m$  and  $|vy| \geq 1$ , such that  $uv^i xy^i z \in L$  for all  $i = 0, 1, 2, \dots$   
 (C) With  $|vxy| \geq m$  and  $|vy| \leq 1$ , such that  $uv^i xy^i z \in L$  for all  $i = 0, 1, 2, \dots$   
 (D) With  $|vxy| \geq m$  and  $|vy| \geq 1$ , such that  $uv^i xy^i z \in L$  for all  $i = 0, 1, 2, \dots$
-

7. A \_\_\_\_\_ point of a fuzzy set  $A$  is a point  $x \in X$  at which  $\mu_A(x) = 0.5$

- (A) Core
- (B) Support
- (C) Cross-over
- (D)  $\alpha$  – cut

8. Match the following

List – I

- (a) Physical layer
- (b) Datalink layer
- (c) Network layer
- (d) Transport layer
- (e) Application Layer

List – II

- (i) Allow resources to network access
- (ii) Move packets from one destination to other
- (iii) Process to process message delivery
- (iv) Transmission of bit stream
- (v) Formation of frames

Codes :

- (A) (a)-(iv), (b)-(v), (c)-(ii), (d)-(iii), (e)-(i)
- (B) (a)-(v), (b)-(iv), (c)-(i), (d)-(ii), (e)-(iii)
- (C) (a)- (i), (b)-(iii), (c)-(ii), (d)-(v), (e)-(iv)
- (D) (a)- (i), (b)-(ii), (c)-(iv), (d)-(iii), (e)-(v)

9. The context free grammar for the language  $L = \{a^n b^m c^k \mid k = |n - m|, n > 0, m > 0, k > 0\}$  is

- (A)  $S \rightarrow S1 S3, S1 \rightarrow aS1 c \mid S2 \mid \lambda, S2 \rightarrow aS2 b \mid \lambda, S3 \rightarrow aS3 b \mid S4 \mid \lambda, S4 \rightarrow bS4 c \mid \lambda$
- (B)  $S \rightarrow S1 S3, S1 \rightarrow aS1S2c \mid \lambda, S2 \rightarrow aS2b \mid \lambda, S3 \rightarrow aS3b \mid S4 \mid \lambda, S4 \rightarrow bS4c \mid \lambda$
- (C)  $S \rightarrow S1 \mid S2, S1 \rightarrow aS1 S2 c \mid \lambda, S2 \rightarrow aS2 b \mid \lambda, S3 \rightarrow aS3 b \mid S4 \mid \lambda, S4 \rightarrow bS4 c \mid \lambda$
- (D)  $S \rightarrow S1 \mid S3, S1 \rightarrow aS1 c \mid S2 \mid \lambda, S2 \rightarrow aS2 b \mid \lambda, S3 \rightarrow a S3 b \mid S4 \mid \lambda, S4 \rightarrow bS4 c \mid \lambda$

10. A Boolean function  $F$  is called self- dual if and only if  $F(x_1, x_2, \dots, x_n) = F(\neg x_1, \neg x_2, \dots, \neg x_n)$  How many Boolean functions of degree  $n$  are self-dual?

- (A)  $2^n$
- (B)  $(2)^{2^n}$
- (C)  $(2)^{n-1}$
- (D)  $(2)^{2^{n-1}}$

11. Big-O estimates for the factorial function and the logarithm of the factorial function i.e.  $n!$  and  $\log n!$  is given by

- (A)  $O(n!)$  and  $O(n \log n)$
- (B)  $O(n^n)$  and  $O(n \log n)$
- (C)  $O(n!)$  and  $O(\log n!)$
- (D)  $O(n^n)$  and  $O(\log n!)$



15. A friend function can be used to
- (A) avoid arguments between classes
  - (B) allow access to classes whose source code is unavailable
  - (C) allow one class to access an unrelated class
  - (D) none of the above
16. Consider the following statements
- (a) Depth - first search is used to traverse a rooted tree.
  - (b) Pre - order, Post-order and Inorder are used to list the vertices of an ordered rooted tree
  - (c) Huffman's algorithm is used to find an optimal binary tree with given weights
  - (d) Topological sorting provides a labelling such that the parents have larger labels than their children. Which of the above statements are true?
- (A) (a) and (d)
  - (B) (c) and (b)
  - (C) (a) (b) and (c)
  - (D) (a) ( b) (c) and (d)
17. Consider a full - adder with the following input values:
- (a)  $x=1, y=0$  and  $C_i$  (carry input) = 0
  - (b)  $x=0, y=1$  and  $C_i = 1$
- Compute the values of S(sum) and  $C_o$  (carry output) for the above input values.
- (A)  $S = 1, C_o = 0$  and  $S = 0, C_o = 1$
  - (B)  $S = 0, C_o = 0$  and  $S = 1, C_o = 1$
  - (C)  $S = 1, C_o = 1$  and  $S = 0, C_o = 0$
  - (D)  $S_o = 0, C_o = 1$  and  $S = 1, C_o = 0$
18. "If my computations are correct and I pay the electric bill, then I will run out of money. If I don't pay the electric bill, the power will be turned off. Therefore, if I don't run out of money and the power is still on, then my computations are incorrect." Convert this argument into logical notations using the variables c, b, r, p for propositions of computations, electric bills, out of money and the power respectively. (Where  $\neg$  means NOT)
- (A) if  $(c \wedge b) \rightarrow r$  and  $\neg b \rightarrow p$ , then  $(\neg r \wedge p) \rightarrow \neg c$
  - (B) if  $(c \vee b) \rightarrow r$  and  $\neg b \rightarrow \neg p$ , then  $(r \wedge p) \rightarrow c$
  - (C) if  $(c \wedge b) \rightarrow r$  and  $\neg p \rightarrow b$ , then  $(\neg r \vee p) \rightarrow \neg c$
  - (D) if  $(c \vee b) \rightarrow r$  and  $\neg b \rightarrow \neg p$ , then  $(\neg r \wedge p) \rightarrow \neg c$

19. What is the output of the following program? (Assume that the appropriate preprocessor directives are included and there is no syntax error)

```
main ( )
{ char S[ ] = "ABCDEFGH";
  printf ("%C", *(&S[3]));
  printf ("%s", S + 4);
  printf ("%u", S);
  /* Base address of S is 1000 */
}
```

- (A) ABCDEFGH1000 (B) CDEFGH1000  
(C) DDEFGHH1000 (D) DEFGH1000
20. Given that  $x = 7.5$ ,  $j = -1.0$ ,  $n = 1.0$ ,  $m = 2.0$  the value of  $--x + j == x > n >= m$  is
- (A) 22.0 (B) 24.1  
(C) 26.2 (D) 28.3
21. An Assertion is a predicate expressing a condition we wish database to always satisfy. The correct syntax for Assertion is
- (A) CREATE ASSERTION 'ASSERTION Name' CHECK 'Predicate'  
(B) CREATE ASSERTION 'ASSERTION Name'  
(C) CREATE ASSERTION, CHECK Predicate  
(D) SELECT ASSERTION
22. For a weak entity set to be meaningful, it must be associated with another entity set in combination with some of their attribute values, is called as
- (A) Neighbour Set (B) Strong Entity Set  
(C) Owner Entity Set (D) Weak Set
23. The inorder and preorder Traversal of binary Tree are dbeafcg and abdecfg respectively. The post-order Traversal is
- (A) dbefacg (B) debfagc  
(C) dbefcga (D) debfgca

24. To determine the efficiency of an algorithm the time factor is measured by
- Counting micro seconds
  - Counting number of key operations
  - Counting number of statements
  - Counting kilobytes of algorithm
25. Match the following port numbers with their uses
- | List – I | List – II          |
|----------|--------------------|
| (a) 23   | (i) World Wide Web |
| (b) 25   | (ii) Remote Login  |
| (c) 80   | (iii) USENET news  |
| (d) 119  | (iv) E – mail      |
- Codes :
- |          |      |       |       |
|----------|------|-------|-------|
| (a)      | (b)  | (c)   | (d)   |
| (A) (iv) | (i)  | (ii)  | (iii) |
| (B) (ii) | (i)  | (iv)  | (iii) |
| (C) (ii) | (iv) | (iii) | (i)   |
| (D) (ii) | (iv) | (i)   | (iii) |
26. What is the size of the 'total length' field in IPv<sub>4</sub> datagram?
- |            |            |
|------------|------------|
| (A) 4 bit  | (B) 8 bit  |
| (C) 16 bit | (D) 32 bit |
27. The translator which performs macro calls expansion is called
- |                           |                           |
|---------------------------|---------------------------|
| (A) Macro processor       | (B) Micro pre – processor |
| (C) Macro pre – processor | (D) Dynamic Linker        |
28. If all the production rules have single non - terminal symbol on the left side, the grammar defined is
- |                          |                               |
|--------------------------|-------------------------------|
| (A) context free grammar | (B) context sensitive grammar |
| (C) unrestricted grammar | (D) phrase grammar            |
29. Let  $P_i$  and  $P_j$  be two processes,  $R$  be the set of variables read from memory and  $W$  be the set of variables written to memory. For the concurrent execution of two processes  $P_i$  and  $P_j$  which of the following conditions is not true?
- |                                 |                                 |
|---------------------------------|---------------------------------|
| (A) $R(P_i) \cap W(P_j) = \Phi$ | (B) $W(P_i) \cap R(P_j) = \Phi$ |
| (C) $R(P_i) \cap R(P_j) = \Phi$ | (D) $W(P_i) \cap W(P_j) = \Phi$ |

30. Match the following

- |                                     |   |
|-------------------------------------|---|
| (a) Size-oriented metrics           | (i) uses number of external interfaces as one of the measurement parameter                                |
| (b) Function-oriented metrics       | (ii) originally designed to be applied to business information systems                                    |
| (c) Extended Function point metrics | (iii) derived by normalizing quality and/or productivity measures by considering the size of the software |
| (d) Function point                  | (iv) uses algorithm characteristics as one of the measurement parameter                                   |

Codes :

- |           |      |       |       |
|-----------|------|-------|-------|
| (a)       | (b)  | (c)   | (d)   |
| (A) (iii) | (iv) | (i)   | (ii)  |
| (B) (ii)  | (i)  | (iv)  | (iii) |
| (C) (iv)  | (ii) | (iii) | (i)   |
| (D) (iii) | (i)  | (iv)  | (ii)  |

31. In the case of parallelization, Amdahl's law states that if  $P$  is the proportion of a program that can be made parallel and  $(1-P)$  is the proportion that cannot be parallelized, then the maximum speed-up that can be achieved by using  $N$  processors is

- |                                   |                                     |
|-----------------------------------|-------------------------------------|
| (A) $\frac{1}{(1-P)+N.P}$         | (B) $\frac{1}{(N-1)P+P}$            |
| (C) $\frac{1}{(1-P)+\frac{P}{N}}$ | (D) $\frac{1}{(P)+\frac{(1-P)}{N}}$ |

32. Which of the following algorithms sort  $n$  integers, having the range 0 to  $(n^2 - 1)$ , in ascending order in  $O(n)$  time?

- |                    |                    |
|--------------------|--------------------|
| (A) Selection sort | (B) Bubble sort    |
| (C) Radix sort     | (D) Insertion sort |



37. A relation  $R = \{A, B, C, D, E, F, G\}$  is given with following set of functional dependencies:  
 $F = \{AD \rightarrow E, BE \rightarrow F, B \rightarrow C, AF \rightarrow G\}$  Which of the following is a candidate key?

- (A)  $A$  (B)  $AB$   
(C)  $ABC$  (D)  $ABD$

38. The number of different spanning trees in complete graph,  $K_4$  and bipartite graph,  $K_{2,2}$  have ----- and ----- respectively.

- (A) 14, 14 (B) 16, 14  
(C) 16, 4 (D) 14, 4

39. Which of the following logic expressions is incorrect?

- (A)  $1 \oplus 0 = 1$  (B)  $1 \oplus 1 \oplus 1 = 1$   
(C)  $1 \oplus 1 \oplus 0 = 1$  (D)  $1 \oplus 1 = 1$

40. The following statement in 'C'

```
int(*f())[];
```

declares

- (A) a function returning a pointer to an array of integers  
(B) a function returning an array of pointers to integers  
(C) array of functions returning pointers to integers  
(D) an illegal statement

41. What is the value returned by the function f given below when  $n=100$ ?

```
int f(int n)
```

```
{ if (n==0) then return n;
```

```
  else
```

```
  return n + f(n-2);
```

```
}
```

- (A) 2550 (B) 2556  
(C) 5220 (D) 5520

42. In a positive-edge-triggered JK flip-flop, if J and K both are high then the output will be ----- on the rising edge of the clock.
- (A) No change (B) Set  
(C) Reset (D) Toggle
43. Consider the following two commands C1 and C2 on the relation R from an SQL database  
C1: drop table R;  
C2: delete from R;  
Which of the following statements is TRUE?
- (I) Both C1 and C2 delete the schema for R.  
(II) C2 retains relation R, but deletes all tuples in R.  
(III) C1 deletes not only all tuples of R, but also the schema for R.
- (A) (I) only (B) (I) and (II) only  
(C) (II) and (III) only (D) (I), (II) and (III)
44. Consider the following operations performed on a stack of size 5:  
Push(a); Pop(); Push(b); Push(c); Pop();  
Push(d); Pop(); Pop(); Push(e);  
Which of the following statements is correct?
- (A) Underflow occurs  
(B) Stack operations are performed smoothly  
(C) Overflow occurs  
(D) None of the above
45. In a fully-connected mesh network with 10 computers, total ----- number of cables are required and ----- number of ports are required for each device.
- (A) 40, 9 (B) 45, 10  
(C) 45, 9 (D) 50, 10
46. Optical fiber uses reflection to guide light through a channel, in which angle of incidence is ----- the critical angle.
- (A) equal to (B) less than  
(C) greater than (D) less than or equal to



52. The Boolean function  $[\sim(\sim p \wedge q) \wedge \sim(\sim p \wedge \sim q)] \vee (p \wedge r)$  is equal to the Boolean function:
- (A)  $q$  (B)  $p \wedge r$   
 (C)  $p \vee q$  (D)  $p$
53. Given  $i = 0, j = 1, k = -1$   
 $x = 0.5, y = 0.0$   
 What is the output of given 'C' expression?  
 $x * 3 \& \& 3 \parallel j \parallel k$
- (A)  $-1$  (B)  $0$   
 (C)  $1$  (D)  $2$
54. Relational database schema normalization is NOT for
- (A) reducing the number of joins required to satisfy a query  
 (B) eliminating uncontrolled redundancy of data stored in the database  
 (C) eliminating number of anomalies that could otherwise occur with inserts and deletes  
 (D) ensuring that functional dependencies are enforced
55. Consider a database table R with attributes A and B. Which of the following SQL queries is illegal?
- (A) `SELECT A FROM R;`  
 (B) `SELECT A, COUNT(*) FROM R;`  
 (C) `SELECT A, COUNT(*) FROM R GROUP BY A;`  
 (D) `SELECT A, B, COUNT(*) FROM R GROUP BY A, B;`
56. Consider the following statements
- $S_1$ : A queue can be implemented using two stacks.  
 $S_2$ : A stack can be implemented using two queues.  
 Which of the following is correct?
- (A)  $S_1$  is correct and  $S_2$  is not correct (B)  $S_1$  is not correct and  $S_2$  is correct  
 (C) Both  $S_1$  and  $S_2$  are correct (D) Both  $S_1$  and  $S_2$  are not correct
57. A network with bandwidth of 10 Mbps can pass only an average of 12,000 frames per minute with each frame carrying an average of 10,000 bits. What is the throughput of this network?
- (A) 1 Mbps (B) 2 Mbps  
 (C) 10 Mbps (D) 12 Mbps

58. Match the following

List – I

- (a) Session layer
- (b) Application layer
- (c) Presentation layer
- (d) Transport layer

List – II

- (i) Virtual terminal software
- (ii) Semantics of the information transmitted
- (iii) Flow control
- (iv) Manage dialogue control

Codes :

- |  |  |
|--|--|
| (A) (a)-(iv), (b)-(i), (c)-(ii), (d)-(iii) | (B) (a)-(i), (b)-(iv), (c)-(ii), (d)-(iii) |
| (C) (a)-(iv), (b)-(i), (c)-(iii), (d)-(ii) | (D) (a)-(iv), (b)-(ii), (c)-(i), (d)-(iii) |

59. The content of the accumulator after the execution of the following 8085 assembly language program, is

```
MVI A, 35H
MOV B, A
STC
CMC
RAR
XRA B
```

- |         |         |
|---------|---------|
| (A) 00H | (B) 35H |
| (C) EFH | (D) 2FH |

60. Which of the following is FALSE?

- (A) The grammar  $S \rightarrow aS|aSbS|\hat{1}$ , where  $S$  is the only non-terminal symbol, and  $\hat{1}$  is the null string, is ambiguous
- (B) An unambiguous grammar has same left most and right most derivation
- (C) An ambiguous grammar can never be LR(k) for any  $k$
- (D) Recursive descent parser is a top-down parser

61. Consider three CPU intensive processes P1, P2, P3 which require 20, 10 and 30 units of time, arrive at times 1, 3 and 7 respectively. Suppose operating system is implementing Shortest Remaining Time first (pre-emptive scheduling) algorithm, then \_\_\_\_\_ context switches are required (suppose context switch at the beginning of Ready queue and at the end of Ready queue are not counted).

- |       |       |
|-------|-------|
| (A) 3 | (B) 2 |
| (C) 4 | (D) 5 |

62. For a program of k variables, boundary value analysis yields \_\_\_\_\_ test cases.

- (A)  $4k - 1$
- (B)  $4k$
- (C)  $4k + 1$
- (D)  $2^k - 1$

63. In Data mining, classification rules are extracted from

- (A) Data
- (B) Information
- (C) Decision Tree
- (D) Database

64. The functions mapping R into R are defined as

$$f(x) = x^3 - 4x, \quad g(x) = 1/(x^2 + 1), \quad \text{and} \quad h(x) = x^4$$

Then find the value of the following composite functions:

hog(x) and hogof(x)

- (A)  $(x^2 + 1)^4$  and  $[(x^3 - 4x)^2 + 1]^4$
- (B)  $(x^2 + 1)^4$  and  $[(x^3 - 4x)^2 + 1]^{-4}$
- (C)  $(x^2 + 1)^{-4}$  and  $[(x^3 - 4x)^2 + 1]^4$
- (D)  $(x^2 + 1)^{-4}$  and  $[(x^3 - 4x)^2 + 1]^{-4}$

65. In propositional logic if  $(P \rightarrow Q) \wedge (R \rightarrow S)$  and  $(P \vee R)$  are two premises such that

$$\frac{\frac{(P \rightarrow Q) \wedge (R \rightarrow S)}{P \vee R}}{Y}$$

Y is the premise:

- (A)  $P \vee R$
- (B)  $P \vee S$
- (C)  $Q \vee R$
- (D)  $Q \vee S$

66. The hexadecimal equivalent of the octal number 2357 is

- (A) 2EE
- (B) 2FF
- (C) 4EF
- (D) 4FE

67. Integrity constraints ensure that changes made to the database by authorized users do not result into loss of data consistency. Which of the following statement(s) is (are) true w.r.t. the examples of integrity constraints?
- (a) An instructor Id. No. cannot be null, provided Instructor Id. No. being primary key.
  - (b) No two citizens have same Adhar-Id.
  - (c) Budget of a company must be zero.
  - (A) (a), (b) and (c) are true
  - (B) (a) false, (b) and (c) are true
  - (C) (a) and (b) are true; (c) false
  - (D) (a), (b) and (c) are false
68. Consider a schema  $R(MNPQ)$  and functional dependencies  $M \rightarrow N$ ,  $P \rightarrow Q$ . Then the decomposition of  $R$  into  $R_1(MN)$  and  $R_2(PQ)$  is
- (A) Dependency preserving but not lossless join
  - (B) Dependency preserving and lossless join
  - (C) Lossless join but not dependency preserving
  - (D) Neither dependency preserving nor lossless join
69. The Octal equivalent of the binary number 1011101011 is
- (A) 7353
  - (B) 1353
  - (C) 5651
  - (D) 5657
70. Match the following Layers and Protocols for a user browsing with SSL :
- | List – I              | List – II |
|-----------------------|-----------|
| (a) Application layer | (i) TCP   |
| (b) Transport layer   | (ii) IP   |
| (c) Network layer     | (iii) PPP |
| (d) Datalink layer    | (iv) HTTP |
- Codes :
- (a) (b) (c) (d)
  - (A) (iv) (i) (ii) (iii)
  - (B) (iii) (ii) (i) (iv)
  - (C) (ii) (iii) (iv) (i)
  - (D) (iii) (i) (iv) (ii)

71. Distance vector routing algorithm is a dynamic routing algorithm. The routing tables in distance vector routing algorithm are updated
- (A) automatically
  - (B) by server
  - (C) by exchanging information with neighbour nodes
  - (D) with back up database
72. Consider the following statements related to compiler construction :
- (I) Lexical Analysis is specified by context-free grammars and implemented by pushdown automata.
  - (II) Syntax Analysis is specified by regular expressions and implemented by finite-state machine.
- Which of the above statement(s) is/are correct?
- (A) Only (I)
  - (B) Only (II)
  - (C) Both (I) and (II)
  - (D) Neither (I) nor (II)
73. Which of the following scheduling algorithms may cause starvation?
- (a) First-come-first-served
  - (b) Round Robin
  - (c) Priority
  - (d) Shortest process next
  - (e) Shortest remaining time first
- (A) (a), (c) and (e)
  - (B) (c), (d) and (e)
  - (C) (b), (d) and (e)
  - (D) (b), (c) and (d)
74. \_\_\_\_\_ refers loosely to the process of semi-automatically analysing large databases to find useful patterns.
- (A) Datamining
  - (B) Data Warehousing
  - (C) DBMS
  - (D) Data mirroring
75. In 3G network, W-CDMA is also known as UMTS. The minimum spectrum allocation required for W-CDMA is
- (A) 2 MHz
  - (B) 20 KHz
  - (C) 5 KHz
  - (D) 5 MHz

76. Negation of the proposition  $\exists x H(x)$  is:
- (A)  $\exists x \neg H(x)$  (B)  $\forall x \neg H(x)$   
 (C)  $\forall x H(x)$  (D)  $\neg x H(x)$
77. Let  $m = (313)_4$  and  $n = (322)_4$ . Find the base 4 expansion of  $m + n$ .
- (A)  $(635)_4$  (B)  $(32312)_4$   
 (C)  $(21323)_4$  (D)  $(1301)_4$
78. In SQL, \_\_\_\_\_ is an Aggregate function.
- (A) SELECT (B) CREATE  
 (C) AVG (D) MODIFY
79. \_\_\_\_\_ SQL command changes one or more fields in a record.
- (A) LOOK-UP (B) INSERT  
 (C) MODIFY (D) CHANGE
80. A list of  $n$  strings, each of length  $n$ , is sorted into lexicographic order using merge - sort algorithm. The worst case running time of this computation is
- (A)  $O(n \log n)$  (B)  $O(n^2 \log n)$   
 (C)  $O(n^2 + \log n)$  (D)  $O(n^3)$
81. What is the output of the following 'C' program? (Assuming little - endian representation of multi-byte data in which Least Significant Byte (LSB) is stored at the lowest memory address.)
- ```
#include <stdio.h>
#include <stdlib.h>
/* Assume short int occupies two bytes of storage */
int main ( )
{
    union saving
    {
        short int one;
        char two[2];
    };
    union saving m;
    m.two [0] = 5;
    m.two [1] = 2;
    printf("%d, %d, %d\n", m.two [0], m.two [1], m.one);
}/* end of main */
```
- (A) 5, 2, 1282 (B) 5, 2, 52  
 (C) 5, 2, 25 (D) 5, 2, 517

82. A software system crashed 20 times in the year 2017 and for each crash, it took 2 minutes to restart. Approximately, what was the software availability in that year?

- (A) 96.9924% (B) 97.9924%  
(C) 98.9924% (D) 99.9924%

83. Which of the following statements is/are True?

P: Refactoring is the process of changing a software system in such a way that it does not alter the external behaviour of the code yet improves the internal architecture.

Q: An example of refactoring is adding new features to satisfy a customer requirement discovered after a project is shipped.

Code:

- (A) P only (B) Q only  
(C) Both P and Q (D) Neither P nor Q

84. In mathematical logic, which of the following are statements?

- (i) There will be snow in January.  
(ii) What is the time now?  
(iii) Today is Sunday.  
(iv) You must study Discrete mathematics.

Choose the correct answer from the code given below:

Code:

- (A) (i) and (iii) (B) (i) and (ii)  
(C) (ii) and (iv) (D) (iii) and (iv)

85. The boolean expression  $A' \cdot B + A \cdot B' + A \cdot B$  is equivalent to

- (A)  $A' \cdot B$  (B)  $(A + B)'$   
(C)  $A \cdot B$  (D)  $A + B$

86. The decimal floating point number  $-40.1$  represented using IEEE-754 32-bit representation and written in hexadecimal form is

- (A) 0xC2206666 (B) 0xC2206000  
(C) 0xC2006666 (D) 0xC2006000

87. Consider a system with 2 level cache. Access times of Level 1 cache, Level 2 cache and main memory are 0.5 ns, 5 ns and 100 ns respectively. The hit rates of Level 1 and Level 2 caches are 0.7 and 0.8 respectively. What is the average access time of the system ignoring the search time within the cache?

- (A) 35.20 ns (B) 7.55 ns  
(C) 20.75 ns (D) 24.35 ns

88. Which method of the Class class is used to determine the name of a class represented by the class object as a String?

- (A) getClass() (B) intern()  
(C) getName() (D) toString()

89. Consider the following boolean equations :

- (i)  $wx + w(x+y) + x(x+y) = x + wy$   
(ii)  $(wx'(y+xz') + w'x')y = x'y$

What can you say about the above equations?

- (A) (i) is true and (ii) is false (B) (i) is false and (ii) is true  
(C) Both (i) and (ii) are true (D) Both (i) and (ii) are false

90. Which sorting algorithm has the worst-case time complexity of  $O(n^2)$  for an array of  $n$  elements?

- (A) Quick Sort (B) Merge Sort  
(C) Bubble Sort (D) Radix Sort

91. Which network topology provides the highest level of fault tolerance?

- (A) Star Topology (B) Ring Topology

(C) Bus Topology

(D) Mesh Topology

92. Which of the following is NOT a valid database isolation level?
- (A) READ COMMITTED (B) SERIALIZABLE  
(C) REPEATABLE READ (D) READ UNCOMMITTED
93. In the context of computer graphics, what does GPU stand for?
- (A) Graph Processing Unit (B) Graphic Pictorial Unit  
(C) Graphical Performance Utility (D) Graphics Processing Unit
94. What is the purpose of an IP address in networking?
- (A) To identify a specific website  
(B) To identify a specific device on a network  
(C) To encrypt data during transmission  
(D) To provide internet connectivity
95. Match the List-I with List-II and choose the correct answer from the code given below
- | List – I           | List – II                                           |
|--------------------|-----------------------------------------------------|
| (a) Equivalence    | (i) $p \Rightarrow q$                               |
| (b) Contrapositive | (ii) $p \Rightarrow q : q \Rightarrow p$            |
| (c) Converse       | (iii) $p \Rightarrow q : \sim q \Rightarrow \sim p$ |
| (d) Implication    | (iv) $p \Leftrightarrow q$                          |
- Codes:
- (A) (a)-(i), (b)-(ii), (c)-(iii), (d)-(iv)  
(B) (a)-(ii), (b)-(i), (c)-(iii), (d)-(iv)  
(C) (a)-(iii), (b)-(iv), (c)-(ii), (d)-(i)  
(D) (a)-(iv), (b)-(iii), (c)-(ii), (d)-(i)
96. A box contains six red balls and four green balls. Four balls are selected at random from the box. What is the probability that two of the selected balls will be red and two will be green?
- (A)  $\frac{1}{14}$  (B)  $\frac{3}{7}$   
(C)  $\frac{1}{35}$  (D)  $\frac{1}{9}$

97. \_\_\_\_\_ is used to find and fix bugs in the Java programs.

- (A) JVM
- (B) JRE
- (C) JDK
- (D) JDB

98. The logic gate that provides high output for same inputs

- (A) NOT
- (B) X-NOR
- (C) AND
- (D) XOR

99. Find the Boolean expression for the logic circuit shown below

(1-NAND gate, 2-NOR gate, 3-NOR gate)

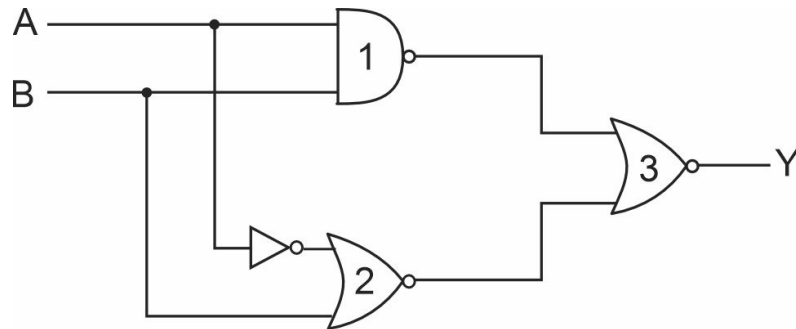

- (A)  $AB'$
- (B)  $A'B$
- (C)  $AB$
- (D)  $A'B'$

100. If a graph (G) has no loops or parallel edges, and if the number of vertices (n) in the graph is  $n \geq 3$ , then graph G is Hamiltonian if

- (i)  $\text{deg}(v) \geq \frac{n}{3}$  for each vertex v
- (ii)  $\text{deg}(v) + \text{deg}(w) \geq n$  whenever v and w are not connected by an edge
- (iii)  $E(G) \geq \frac{1}{3}(n-1)(n-2)+2$

Choose the correct answer from the code given below:

Code:

- (A) (i) and (iii) only
- (B) (ii) only
- (C) (ii) and (iii) only
- (D) (iii) only

101. The prefix form of an infix expression  $p+q-r*t$  is

- (A)  $+pq-rt$  (B)  $-+pqr*t$   
 (C)  $-+pq*rt$  (D)  $-+*pqrt$

102. The prefix form of  $A-B/(C*D^E)$  is

- (A)  $-/*^ACBDE$  (B)  $-ABCD*^DE$   
 (C)  $-A/B*C^DE$  (D)  $-A/BC*^DE$

103. An algorithm is made up of two independent time complexities  $f(n)$  and  $g(n)$ . Then the complexities of the algorithm is in the order of

- (A)  $f(n) \times g(n)$  (B)  $Max(f(n), g(n))$   
 (C)  $Min(f(n), g(n))$  (D)  $f(n) + g(n)$

104. The goal of hashing is to produce a search that takes

- (A)  $O(l)$  time (B)  $O(n^2)$  time  
 (C)  $O(\log n)$  time (D)  $O(n \log n)$  time

105. A band is always equivalent to

- (A) A byte (B) A bit  
 (C) 100 bits (D) None of these

106. When the receiver sees five consecutive incoming '1' bits followed by a '0' bit it automatically destuffs \_\_\_\_\_ in bit stuffing.

- (A) '1' bit (B) '0' bit  
 (C) '01' bit (D) '10' bit

107. Which statement gets affected when  $i++$  is changed to  $++i$ ?

- (A)  $i = 20; i++;$  (B)  $\text{for } (i = 0; i < 20; i++) \{ \}$   
 (C)  $a = i++;$  (D)  $\text{while } (i++ = 20) \text{ cout} << i;$

108. Consider the following grammars :

$$G_1 : S \rightarrow aSb | bSa | aa$$

$$G_2 : S \rightarrow aSb | bSa | SS | \lambda$$

$$G_3 : S \rightarrow aSb | bSa | SS | a$$

$$G_4 : S \rightarrow aSb | bSa | SS | SSS | \lambda$$

Which of the following is correct w.r.t. the above grammars?

- (A)  $G_1$  and  $G_3$  are equivalent (B)  $G_2$  and  $G_3$  are equivalent  
(C)  $G_2$  and  $G_4$  are equivalent (D)  $G_3$  and  $G_4$  are equivalent

109. Which of the following conditions is NOT a necessary condition for a deadlock to occur?

- (A) Mutual Exclusion (B) Hold and Wait  
(C) Preemption (D) Circular Wait

110. A tree has  $2n$  vertices of degree 1,  $3n$  vertices of degree 2,  $n$  vertices of degree 3. Determine the number of vertices and edges in tree.

- (A) 12, 11 (B) 11, 12  
(C) 10, 11 (D) 9, 10

111. Which deadlock prevention technique requires processes to request and be allocated all the resources they need before they start execution?

- (A) Circular Wait Prevention (B) Hold and Wait Prevention  
(C) Mutual Exclusion Prevention (D) No Preemption Prevention

112. For a statement

A language  $L \subseteq \Sigma^*$  is recursive if there exists some turing machine  $M$ .

Which of the following conditions is satisfied for any string  $\omega$  ?

- (A) If  $\omega \in L$ , then  $M$  accepts  $\omega$  and  $M$  will not halt  
(B) If  $\omega \notin L$ , then  $M$  accepts  $\omega$  and  $M$  will halt by reaching at final state  
(C) If  $\omega \notin L$ , then  $M$  halts without reaching to acceptable state  
(D) If  $\omega \in L$ , then  $M$  halts without reaching to an acceptable state

---

113. Given two tables

EMPLOYEE (EID, ENAME, DEPTNO)

DEPARTMENT (DEPTNO, DEPTNAME)

Find the most appropriate statement of the given query:

```
Select count (*) 'total'
```

```
from EMPLOYEE
```

```
where DEPTNO IN (D1, D2)
```

```
group by DEPTNO
```

```
having count (*) > 5
```

- (A) Total number of employees in each department D1 and D2
- (B) Total number of employees of department D1 and D2 if their total is >5
- (C) Display total number of employees in both departments D1 and D
- (D) The output of the query must have atleast two rows

114. A micro instruction format has micro operation field which is divided into 2 subfields F1 and F2, each having 15 distinct micro operations, condition field CD for four status bits, branch field BR having four options used in conjunction with address field AD. The address space is of 128 memory words. The size of micro instruction is

- (A) 19
- (B) 18
- (C) 17
- (D) 20

115. Batch processing is characterized by

- (A) Real-time processing
- (B) Immediate user interaction
- (C) Processing tasks in sequential order
- (D) Continuous user involvement



---

116. What does the following function f() in 'C' return?

```
int f(unsigned int N)
{
    unsigned int counter = 0;
    while(N > 0)
        { counter += N & 1;
          N = N >> 1;
        }
    return counter == 1;
}
```

- (A) 1 if N is odd, otherwise 0
- (B) 1 if N is a power of 2, otherwise 0
- (C) 1 if the binary representation of N is all 1's, otherwise 0
- (D) 1 if the binary representation of N has any 1's, otherwise 0

117. You can detect spelling and grammar error by

- (A) Press Shift + F7
- (B) Press F7
- (C) Press Ctrl + F7
- (D) Press Alt + F7

118. Multiprogramming involves

- (A) Executing one program at a time
- (B) Running multiple programs simultaneously
- (C) Operating in real-time only
- (D) Processing tasks in a sequential manner

119. Which term is used to describe the growth rate of an algorithm's running time as the input size increases?

- (A) Efficiency
- (B) Complexity
- (C) Optimality
- (D) Simplicity

120. A function inside another function is called

- (A) Nested function
- (B) Round function
- (C) Sum function
- (D) Text function

121. Time-sharing systems are designed to
- (A) Run a single program at a time
  - (B) Execute programs in a sequential manner
  - (C) Share computing resources among multiple users
  - (D) Optimize real-time data processing
122. What is the primary difference between multiprogramming and time-sharing systems?
- (A) The number of programs executed simultaneously
  - (B) The speed of program execution
  - (C) The type of operating system used
  - (D) The availability of hardware resources
123. What is a key advantage of using a time-sharing system?
- (A) Improved security mechanisms
  - (B) Faster program execution
  - (C) Enhanced resource utilization
  - (D) Real-time data analysis
124. What is the primary purpose of a symbol table in a compiler?
- (A) To store intermediate code
  - (B) To store program documentation
  - (C) To manage and store information about symbols
  - (D) To execute the program
125. \_\_\_\_\_ signal varies continuously over space and/or time.
- (A) Analog
  - (B) Digital
  - (C) Monolog
  - (D) Multilog
126. In Real Time Interactive Audio Video, conferencing requires two way communication between
- (A) Pixels to packets
  - (B) Receivers and senders
  - (C) Packet to frames
  - (D) Frames to pixels
127. In Real Time Interactive Audio Video, Jitter is introduced in real-time data by delay between
- (A) Pixels
  - (B) Layers
  - (C) Frames
  - (D) Packets

- 
128. Session Initiation Protocol (SIP), has a mechanism that finds the
- (A) ip address
  - (B) terminal
  - (C) domain
  - (D) way
129. What is the purpose of code generation in a compiler?
- (A) To convert high-level code to assembly code
  - (B) To perform syntax analysis
  - (C) To create program documentation
  - (D) To store program variables
130. How are symbol tables and code generation related in a compiler?
- (A) Symbol tables are used to store code generated during compilation
  - (B) Code generation involves creating symbol tables
  - (C) Symbol tables are generated from assembly code
  - (D) They are unrelated components of a compiler
131. Characteristic of a multimedia system has followed which of the following?
- (A) High data rates
  - (B) Low rates
  - (C) High storage
  - (D) Both (A) and (C)
132. Which of the following is correct in the multimedia system require hard real-time scheduling to?
- (A) Deliver the media file to the client
  - (B) Ensure critical tasks will be serviced within timing deadlines
  - (C) Security
  - (D) Minimize the delay
133. Audio compression can be used for
- (A) Voice and data
  - (B) Video and voice
  - (C) Speech or music
  - (D) Picture and colors

- 
134. In Session Initiation Protocol (SIP) establishing session requires three way
- (A) Handshake (B) Ports  
(C) System (D) Protocols
135. Which type of loop executes the loop body at least once, regardless of the condition?
- (A) For loop (B) While loop  
(C) Do-while loop (D) Repeat loop
136. In object-oriented programming, an object is a combination of
- (A) Data and functions (B) Loops and conditions  
(C) Libraries and modules (D) Pointers and addresses
137. HTML stands for
- (A) Hyper Text Markup Language (B) High-Level Text Mode Language  
(C) Human Task Management Language (D) Hyper Transfer Mode Language
138. What is the main function of a search engine?
- (A) Displaying advertisements  
(B) Displaying news articles  
(C) Indexing and retrieving web pages  
(D) Creating web pages
139. What is the purpose of bookmarks in web browsers?
- (A) To display news articles  
(B) To create new web pages  
(C) To save and easily access favorite web pages  
(D) To send emails
140. What is the purpose of splitting a web page into frames?
- (A) To increase the loading speed of the page  
(B) To make the page visually appealing  
(C) To enhance security  
(D) To display multiple web pages within a single page

- 
141. In programming, what does it mean to "clear a list"?
- (A) Remove an item from the list                      (B) Rearrange the items in the list  
(C) Delete the list entirely                              (D) Remove all items from the list
142. Which logical operator is used to perform logical NOT?
- (A) &&                                                              (B) ||  
(C) !                                                                (D) ^
143. What is a function in programming?
- (A) A piece of data  
(B) A block of code that performs a specific task  
(C) A loop structure  
(D) A data type
144. In object-oriented programming, what is a class?
- (A) A built-in data type                                      (B) A function that returns multiple values  
(C) A block of code                                              (D) A blueprint for creating objects
145. In C++, how is function overloading achieved?
- (A) By using the same function name with different return types  
(B) By using the same function name with different parameter types or numbers  
(C) By converting functions from C to C++  
(D) By creating nested functions
146. How is method overriding achieved in Java?
- (A) By using the same method name with different return types  
(B) By using the same method name with different parameter types or numbers  
(C) By converting methods from C++ to Java  
(D) By creating nested methods
147. In C++, which keyword is used to allocate memory for an object dynamically?
- (A) new                                                              (B) dynamic  
(C) alloc                                                              (D) malloc

148. In object-oriented programming, what is the term for creating a new class based on an existing class?
- (A) Class generation (B) Class expansion  
(C) Class inheritance (D) Class override
149. Which library functions are commonly used to perform file input and output operations in C++?
- (A) read() and write() (B) cin and cout  
(C) input() and output() (D) fopen() and fprintf()
150. What is one of the key benefits of Object-Oriented Programming (OOPs)?
- (A) Faster execution of programs  
(B) Eliminates the need for loops  
(C) Reusability of code and modular design  
(D) Increases memory usage
151. Parsing is also known as?
- (A) Syntax analysis (B) Lexical analysis  
(C) Semantic analysis (D) None of the above
152. Predictive parsers can be?
- (A) Constructive (B) Recursive  
(C) Non recursive (D) Both (A) and (B)
153. Business application programs include
- (A) Expert systems  
(B) Drill-and practice programs  
(C) Tax planning and preparation programs  
(D) All of these
154. What is the purpose of using reverse video feature in menu driven programs?
- (A) To enhance contrast  
(B) To make it user friendly  
(C) To improve visibility  
(D) To highlight a menu prompt

- 
155. Which of the following is not a characteristic of the conventional process of developing application system?
- (A) Slow implementation of system change
  - (B) Very long time span of development
  - (C) Minimized maintenance of application software
  - (D) Increasing labour cost for programming and system analysis
156. Choose the odd one out.
- (A) Interpreter
  - (B) Compiler
  - (C) Programmer
  - (D) Operating system
157. Which of the following is also known as presentation software that is used to give presentation of information and pictures through slideshows?
- (A) Multimedia authoring
  - (B) Desktop publishing
  - (C) Presentation graphics
  - (D) Both (B) and (C)
158. Which utility software is used to protect the computer system from hackers?
- (A) Antivirus
  - (B) Firewall
  - (C) AUP
  - (D) Backup wizard
159. Which of the following Windows utilities scans the entire hard drive and erase (or delete) any unnecessary files such as temporary files from the Internet, and cookies downloaded while visiting webpages?
- (A) Disk defragmenter
  - (B) Disk cleanup
  - (C) Backup and Restore wizard
  - (D) All of the above

160. A computer virus that attacks an antivirus program to prevent detection of the virus in the computer system is
- (A) Worm (B) Retrovirus  
(C) Trojan (D) Ghost virus
161. Which of the following is the purpose for using clipping in computer graphics?
- (A) Copying (B) Zooming  
(C) Adding graphics (D) Removing objects and lines
162. Which of the following is defined as the number of pixels stored in the frame buffer of a graphics system?
- (A) Resalution (B) Resolution  
(C) Depth (D) None of the mentioned
163. Which of the following is defined as the drawing of number of copies of the same image in rows and columns across the interface window so that they cover the entire window?
- (A) Zooming (B) Panning  
(C) Tiling (D) Roaming
164. What does an aspect ratio mean?
- (A) Ratio of vertical points to horizontal points  
(B) Ratio of vertical points to horizontal points and horizontal points to vertical points  
(C) Number of pixels  
(D) Ratio of horizontal points to vertical points

- 
165. Which of the following is known as the window opened on the raster graphics screen in which the image will be displayed?
- (A) Interface window (B) World window  
(C) World co-ordinate system (D) Screen co-ordinate system
166. The activity that distributes estimated effort across the planned project duration by allocating the effort to specific software developing tasks is
- (A) Project scheduling (B) Detailed schedule  
(C) Macroscopic schedule (D) None of the mentioned
167. Which component of a microprocessor is responsible for performing arithmetic and logical operations?
- (A) Control Unit (B) ALU (Arithmetic Logic Unit)  
(C) Memory Unit (D) Input-Output Unit
168. Which microprocessor architecture is commonly used in personal computers and laptops?
- (A) ARM (B) RISC-V  
(C) MIPS (D) x86
169. The microprocessor's clock speed is measured in
- (A) Megabytes (B) Gigahertz  
(C) Kilobytes (D) Terabytes
170. Which generation of microprocessors introduced the concept of 64-bit processing?
- (A) 1st Generation (B) 2nd Generation  
(C) 3rd Generation (D) 4th Generation

171. The microprocessor's architecture developed by Intel and used in most modern computers is known as

- (A) ARM (B) RISC-V  
(C) x86 (D) MIPS

172. In C programming, a pointer is a variable that stores the

- (A) Value of another pointer (B) Address of another variable  
(C) Value of a constant (D) Size of an array

173. What is the output of the following code snippet?

```
```c
#include <stdio.h>
void recursiveFunction(int n) {
    if (n > 0) {
        recursiveFunction(n - 1);
        printf("%d ", n);
    }
}
int main() {
    recursiveFunction(5);
    return 0;
}
```
```

- (A) 5 4 3 2 1 (B) 1 2 3 4 5  
(C) 1 2 3 4 (D) 5 4 3 2

174. Which operator is used to access the value stored at the address pointed to by a pointer?

- (A) & (B) \*  
(C) \$ (D) %

- 
175. Recursion in C programming allows a function to call itself
- (A) Indefinitely (B) Once  
(C) Twice (D) Thrice
176. What is the purpose of dynamic memory allocation in C programming using pointers?
- (A) To allocate memory for global variables  
(B) To allocate memory for local variables  
(C) To allocate memory during runtime for data structures  
(D) To deallocate memory for functions
177. Which data structure has a fixed size and continuous memory allocation?
- (A) Arrays (B) Linked Lists  
(C) Stacks (D) Queues
178. In a linked list, each element is called a
- (A) Cell (B) Node  
(C) Link (D) Vertex
179. What is the time complexity for accessing an element in an array?
- (A)  $O(1)$  (B)  $O(n)$   
(C)  $O(\log n)$  (D)  $O(n^2)$
180. Which operation is NOT typically performed on a linked list?
- (A) Insertion (B) Deletion  
(C) Random Access (D) Traversal
181. Which parsing technique is used to analyze the source code from left to right and builds a derivation from the start symbol to the input string?
- (A) Top-Down Parsing (B) Bottom-Up Parsing  
(C) Recursive Parsing (D) Predictive Parsing

182. Which phase of the compiler is responsible for breaking the source code into meaningful tokens?
- (A) Lexical Analysis (B) Syntax Analysis  
(C) Semantic Analysis (D) Code Generation
183. Which parsing technique involves constructing the parse tree from the leaves towards the root?
- (A) Top-Down Parsing (B) Bottom-Up Parsing  
(C) Recursive Descent Parsing (D) Shift-Reduce Parsing
184. The phase of the compiler that checks whether the source code follows the rules of the programming language is
- (A) Lexical Analysis (B) Syntax Analysis  
(C) Semantic Analysis (D) Code Optimization
185. Which parsing technique involves reducing a series of input symbols to a production using a set of grammar rules?
- (A) Top-Down Parsing (B) Bottom-Up Parsing  
(C) Recursive Descent Parsing (D) Shift-Reduce Parsing
186. Which concept allows a computer to use more main memory space than is physically available?
- (A) Multithreading (B) Virtual Memory  
(C) Process Scheduling (D) Parallel Processing
187. Which algorithm aims to minimize the average waiting time in process scheduling?
- (A) FCFS (First-Come-First-Served) (B) SJF (Shortest Job First)  
(C) Round Robin (D) Priority Scheduling
188. What is the purpose of the page replacement policy in virtual memory?
- (A) To optimize disk space usage  
(B) To manage process scheduling  
(C) To minimize the number of CPU cycles

---

(D) To manage swapping of processes between main memory and disk

189. Which process scheduling algorithm provides equal time slices to each process in a round-robin manner?
- (A) FCFS (First-Come-First-Served)                      (B) SJF (Shortest Job First)  
(C) Round Robin                                                      (D) Priority Scheduling
190. Which statement best describes the purpose of virtual memory?
- (A) To provide additional physical memory to the computer system  
(B) To improve the processing speed of the CPU  
(C) To eliminate the need for secondary storage devices  
(D) To create an illusion of a larger memory than physically available
191. What is the primary goal of information system security?
- (A) Maximizing profits  
(B) Minimizing user access  
(C) Ensuring confidentiality, integrity, and availability of data  
(D) Reducing hardware costs
192. A firewall is used to
- (A) Increase network speed                                      (B) Prevent unauthorized access to a network  
(C) Provide extra storage space                                      (D) Optimize search engine results
193. What is the term used to describe the process of converting plaintext into unreadable ciphertext to secure it?
- (A) Encryption                                                              (B) Authentication  
(C) Firewalling                                                              (D) Compression
194. Which type of attack involves an attacker attempting to exhaust all available network resources of a system?
- (A) Phishing                                                                      (B) Denial of Service (DoS)  
(C) Malware                                                                      (D) Encryption

---

195. What is the purpose of Two-Factor Authentication (2FA) in information security?

- (A) To use two different firewalls
- (B) To prevent malware attacks
- (C) To provide access to sensitive data
- (D) To enhance authentication by requiring two verification methods

196. C++ is an example of which type of programming language?

- (A) Procedural
- (B) Functional
- (C) Object-Oriented
- (D) Logical

197. Which of the following is true about Java?

- (A) Java is a compiled language only
- (B) Java applications are platform-dependent
- (C) Java supports automatic memory management
- (D) Java does not support object-oriented programming

198. Java applications are compiled into

- (A) Machine code
- (B) Assembly code
- (C) Bytecode
- (D) High-level code

199. Which of the following is an example of a derived data type?

- (A) Integer
- (B) Character
- (C) Array
- (D) Float

200. In programming, what are derived types?

- (A) Data types created by the compiler
- (B) Complex data types built from primitive data types
- (C) Types that cannot be used in inheritance
- (D) Reserved keywords in programming languages



---

ROUGH WORK

